

uniclass L393:P71	EPIC E196:X71
CI/SfB (49)	Xn6

ORAC[®]

DECOR

EXTERIOR COLLECTION

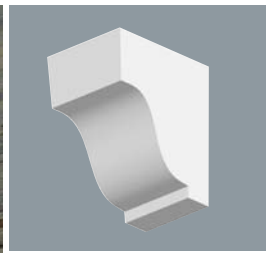



FC01
80 x 350 x 390mm
3⁵/₃₂" x 13²⁵/₃₂" x 15¹¹/₃₂"



GB02
70 x 490 x 400mm
2³/₄" x 19⁹/₃₂" x 15³/₄"
- structural max. 35kg*
- white wood grain finish

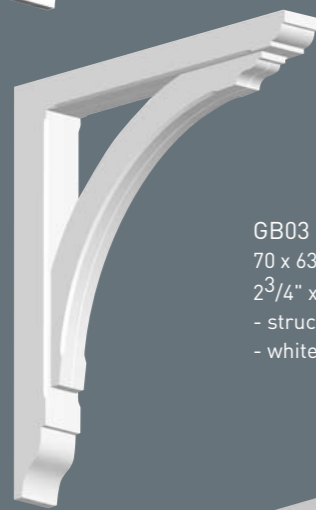
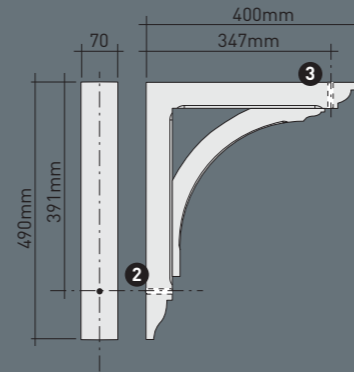

GB03
70 x 630 x 580mm
2³/₄" x 24¹³/₁₆" x 22⁷/₈"
- structural max. 75kg*
- white wood grain finish

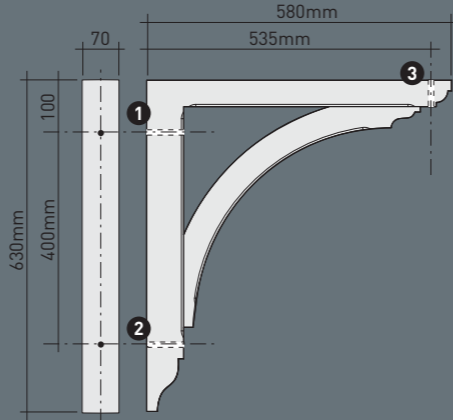

GB04
50 x 745 x 770mm
2" x 29⁵/₁₆" x 30⁵/₁₆"
- structural max. 75kg*
- white wood grain finish

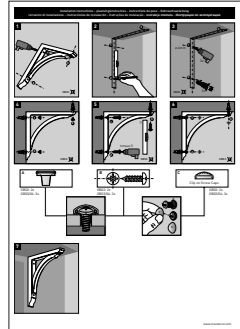
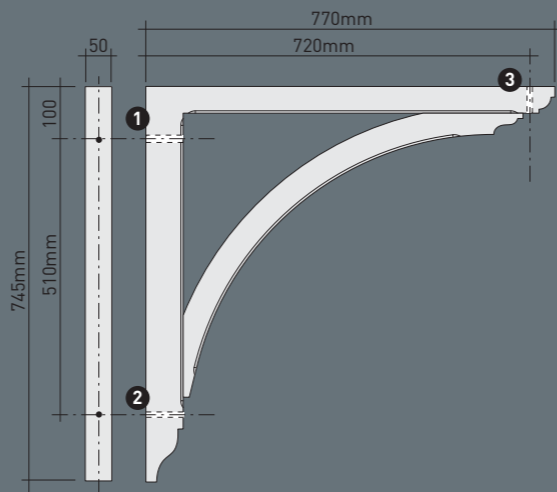

installation instructions
are available



white woodgrain finish

BRACKETS



GB04



GB03



GB02



GB02



FC01

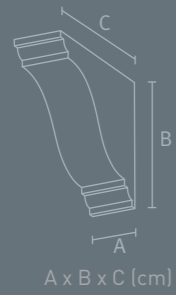

TF01 (180° rotated) *
7,7 x 12,3 x 35cm

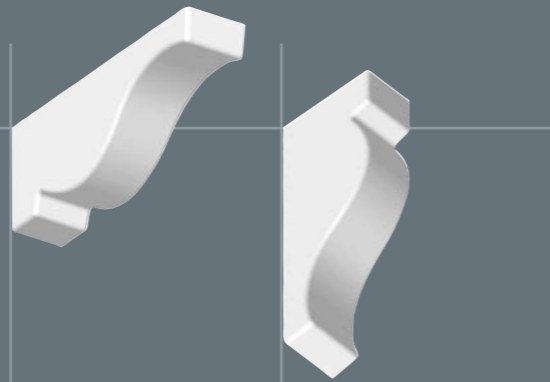

TF02 (180° rotated) *
7,7 x 12 x 10,5cm



TF03 (180° rotated) *
7,8 x 10 x 20cm

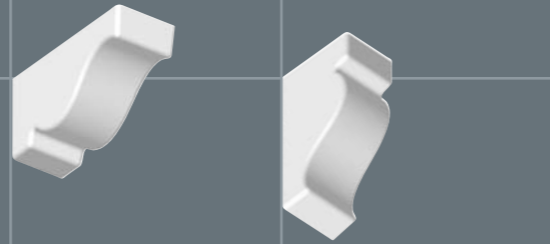

TF04 (180° rotated) *
7,7 x 25 x 20cm

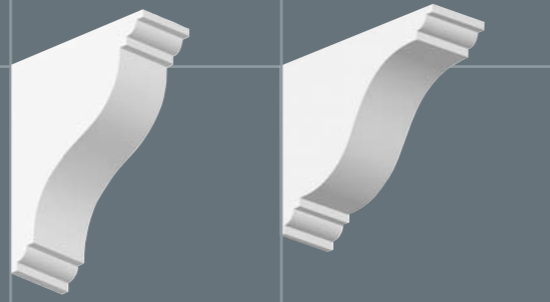

TF05 (180° rotated) *
10 x 13,5 x 25,5cm

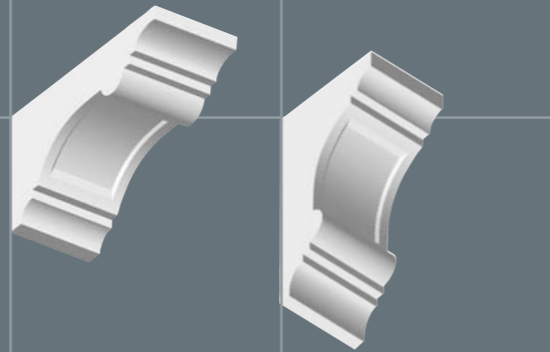

TF06 (180° rotated) *
15,5 x 7,5 x 17,5cm

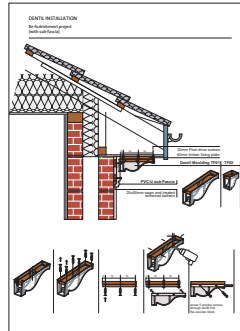
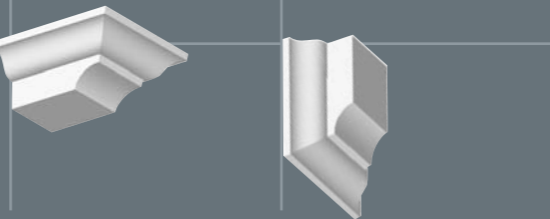

installation instructions
are available







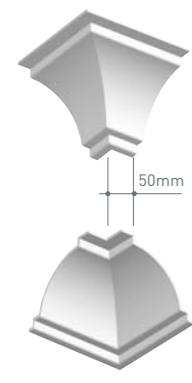

DENTILS

* Fixing 180° rotated may also require the use of FDP700 (see back cover).

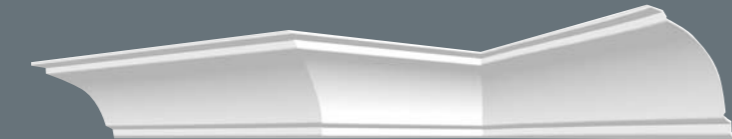
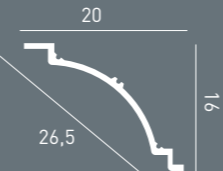
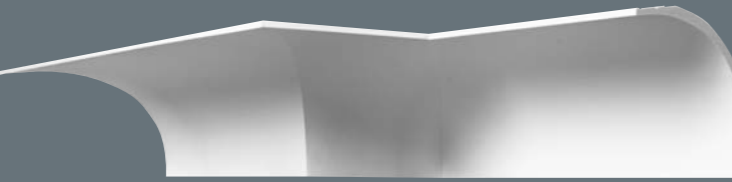
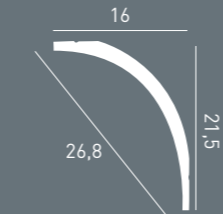
C820/A
outer corner 90°

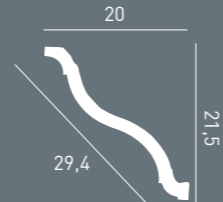

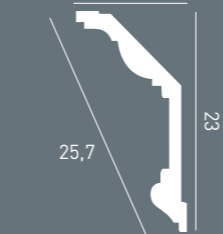
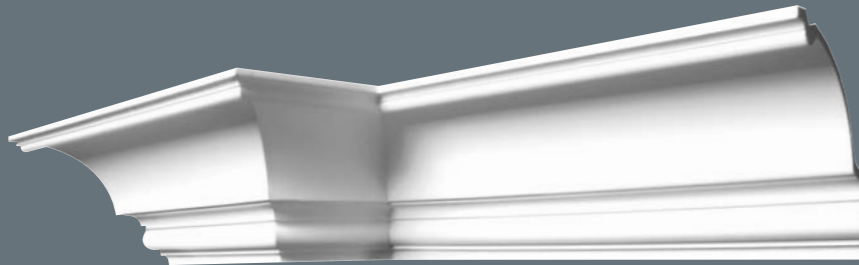
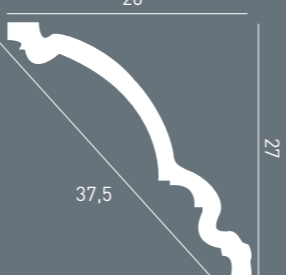
C820/B
inner corner 90°

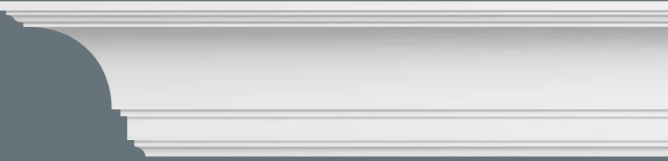
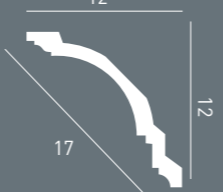
	C800 - L = 2000mm - 6'6"	
	C820 - L = 2440mm - 8'	
	C890 - L = 2000mm - 6'6"	
	C835 - L = 2000mm - 6'6"	
	C832 - L = 2000mm - 6'6"	
	C836 - L = 2000mm - 6'6"	
ORAC AXXENT		
	CX826 - L = 2000mm - 6'6"	
	CX806 - L = 2000mm - 6'6"	



COVING

All products above are designed for external use.

Columns

Have a look at our columns range at www.oracdecor.com



DecoFix

PUROTOUCH® / DUROPOLYMER®



Hydro
extra strong
installation
adhesive
for exterior

For exterior applications, in damp environments and on non-porous surfaces, between the mouldings and the wall and/or ceiling. Any overspill needs to be painted to avoid discolouration.

FDP700 290 ml for 7 à 8 m

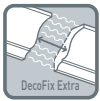

Extra
Adhesive
for perfect
jointing

A glue for seam joints between the mouldings. Push the profiles strongly to each other and remove excess of DecoFix Extra preferably before hardening (wait at least two hours) with acetone or Synth Thinner. The adhesive can be painted after 24 hrs.

FX200 310 ml for min. 80m

FX210 80 ml for min. 20m



Full warranty coverage if provided instructions have been followed to the letter.



Recyclable.
ORAC manufacture
zero waste



CFC free

As the world leader in high quality architectural mouldings Orac has invested substantially to reduce their carbon footprint. Solar energy provides a large part of the energy needed to produce the products. All Duropolymer® products are 100% recyclable. None of the products contain toxic gasses and all of the products are produced without CFC's. Waste material is returned to a granular form and used to produce new products.

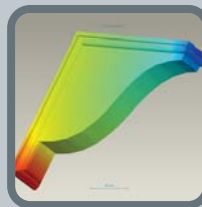
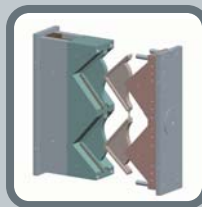

CHARACTERISTICS



Easy to cut
and install



Sharp lines
for an optimal
design



Water resistant.
Resistant to most
common solvents
and moisture



Splitting
resistant, no
deterioration,

INSTALLATION



Use only DecoFix Hydro
en DecoFix Extra for
perfect installation
and warranty

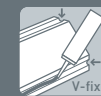

Integrated
V-fix for
easy glueing

ORAC (UK) Ltd.

Unit 5, Hewitts Estate
Elmbridge Road
Cranleigh, Surrey
GU6 8LW
United Kingdom
Tel: +44 (0)1483-271 211
Fax: +44 (0)1483-278 317
uk@oracdecor.com

ORAC Headquarter

nv ORAC sa
Biekorfstraat 32
B-8400 Oostende
Tel: +32 (0)59-80 32 52
Fax: +32 (0)59-80 28 10
sales@oracdecor.com
www.oracdecor.com